

Transformer Loading & Thermal Design Considerations

46TH Annual UTA TSDOS

SEPTEMBER 2013



Transformer Loading & Thermal Design Considerations

YOUR PRESENTER:

John Prunte

Director of Engineering Technical Support
SPX Transformer Solutions, Inc.

Office: 214-637-4434

Cell: 817-300-6843

John.Pruente@spx.com

John joined SPX Transformer Solutions in June 1999, where his engineering and technical support responsibility spans the Service and Components Division. Prior to SPX, he was employed by Duke Energy, where he was responsible for all aspects of transformer maintenance, development of new maintenance methods and standards as well as analysis and reporting.

- Thermal Design Considerations
- Industry Practice on Transformer Loading
- Theoretical Life
- Functional Life
- Monitoring
- Conclusions
- Questions & Discussion

Transformer Losses

- No Load Losses
 - By-product of energizing (exciting) the core
 - Function of the grade of core steel used, design induction level and operating voltage
 - Remains constant for varying load

- Load Losses
 - I^2R - Varies with loading and is proportional to the square of the current flowing through the winding conductor
 - Function of conductor material and cross sectional dimension
 - Stray (windings) – Result of circulating currents (eddy) within the conductor due to leakage flux
 - Stray (other) – Result of circulating currents in tank, core clamps and other magnetic steel components

Transformer losses generate heat

- **Liquid Temperature Rise**
Liquid temperature rise above ambient measured in a heat run test shall be determined as equal to top liquid temperature minus half the difference in temperature at the top and bottom of the cooling radiators or coolers (typically 65°C maximum)
- **Average Winding Temperature Rise**
Average winding temperature of a winding phase shall be determined from the windings hot resistance at shutdown of a heat run test and is related to winding current density and the amount of conductor surface exposed to the surrounding oil in the windings (typically 65°C maximum)
- **Winding Hottest-Spot**
The highest temperature of a transformer winding is effected by stray flux and is greater than the average winding temperature (typically 80°C maximum)

Source: ANSI C57.12.00-2010

Example Hot-Spot Temperature Calculation

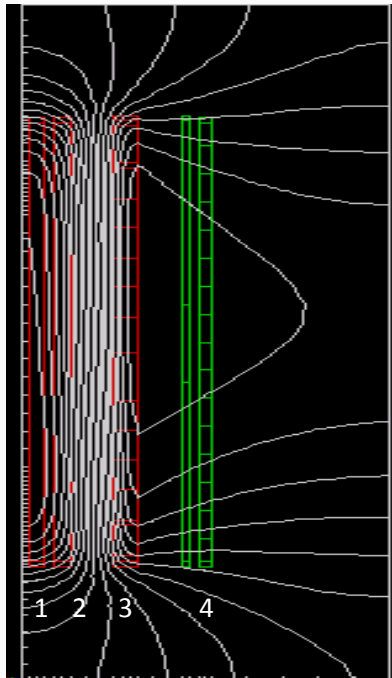

28 kV, 175.5 kV

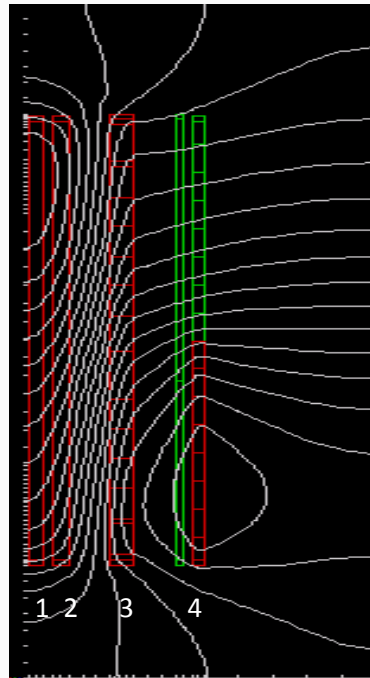

28 kV, 195.5 kV

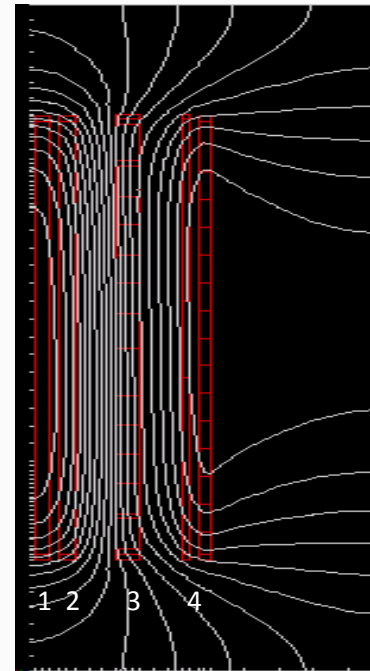

28 kV, 255.5 kV

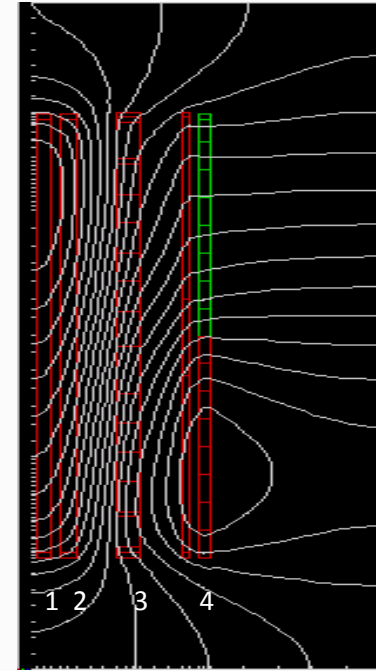

28 kV, 235.5 kV

	Hot-Spot Temperature (°C Rise over ambient)				Hottest
	@ 175.5 kV	@ 195.5 kV	@ 255.5 kV	@ 235.5 kV	
Winding 1	84.1	83.9	88.4	86.1	88.4
Winding 2	77.0	76.9	79.8	78.4	79.8
Winding 3	80.9	77.0	71.2	72.7	80.9
Winding 4	65.7	65.7	70.0	69.8	70.0

Windings 1 and 3 had to be redesigned to lower the hot-spot temperature rise below 80 °C.

Transformer Factory Heat Run Test Data

THERMAL TESTS

Temperature Rises are in °C and corrected to instant of shut down.
 Transformer connected and loaded as follows:
 All winding currents are listed at maximum MVA at which thermal tests are performed.

HV: 131.1 kV 110 Amps LV: 11.78Y kV 1225 Amps

Oil flow in windings: Non Directed

Harmonic Factor: Equal to or less than 5%. Test Results below are from exact duplicate WT00447

Heat Run temperature **Rise Over Ambient** (All temperatures measured in °C)

*The maximum (hottest-spot) winding temperature rises above ambient temperature was determined per sub clause 5.11.1.1 C of the IEEE Standard C57.12.00-2006.

MVA	Top Oil	Bottom Oil	HV Wdg	LV Wdg	TV Wdg.	Guar	Average Ambient Temp	*Calc Hottest-Spot Winding Rise over Ambient Temp	Radiator Qty	Fan Qty	Total Losses Kilo Watts
15	44.2	27.8	41.4	46.5	-	65	27.9	56.4	5	1	95.5
25	50.0	20.7	49.0	55.2	-	65	29.0	73.6	5	7 ¹	238.5
31.25**	59.9	23.4	57.3	65.8	-	-	31.3	88.4	5	7 ²	365.4

** 125% Over load Heat run.

¹ With 1140-RPM fans

² With 1725-RPM fans



TO CONTROL	DESIGN PARAMETER
Average liquid temperature rise over ambient	Cooling equipment — radiators or coolers, number / CFM rating of fans, pumps
Average winding temp rise over ambient	Winding current density, conductor size, number of radial spacers, cooling ducts, directed flow
Winding hottest spot temp rise over ambient	Winding current density, stray flux

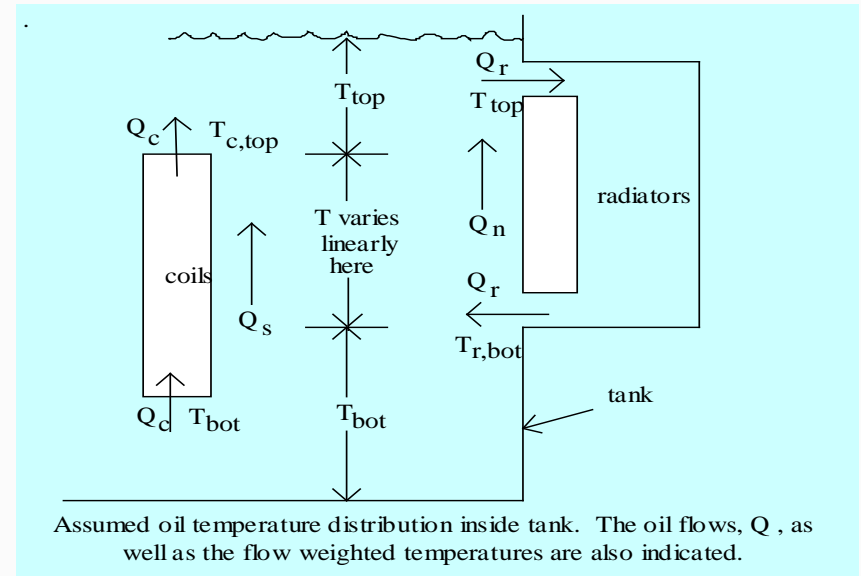

Three Principles of Heat Transfer

1. Convection

Requires contact between the heat source (the winding conductors which are heated by their losses, I^2R stray and eddy currents) and the mineral oil, heating the oil.

2. Conduction

The heated mineral oil transfers this oil to the radiators where the oil will warm the radiator cooling fins by the conduction process.

3. Radiation

The fins radiate heat to the ambient air, cooling the transformer by cooling the oil.

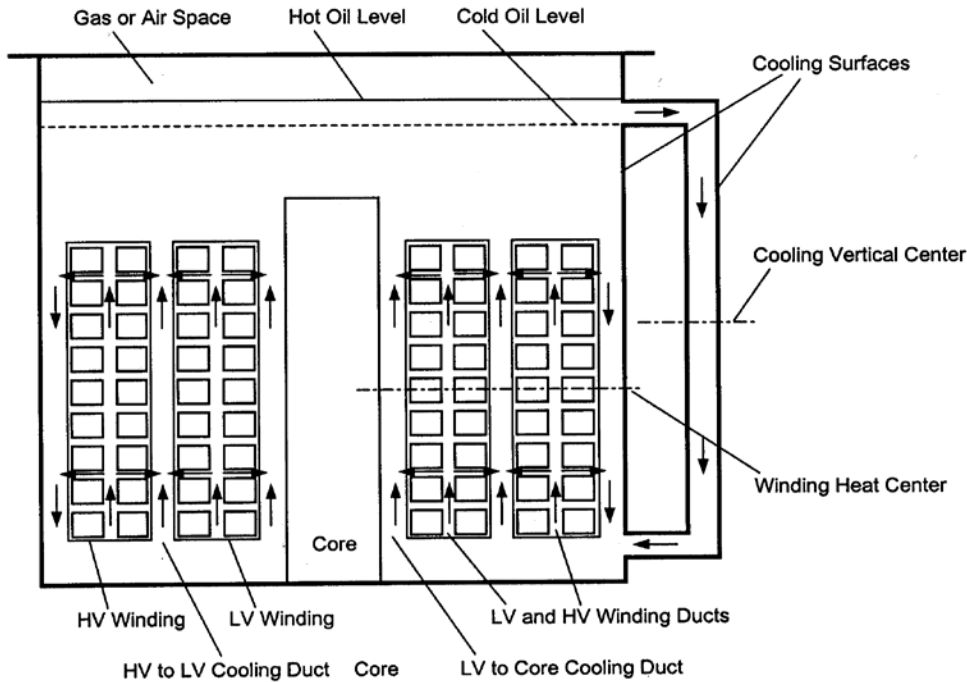

Arrows represent the typical flow patterns of oil circulation in the windings and tank

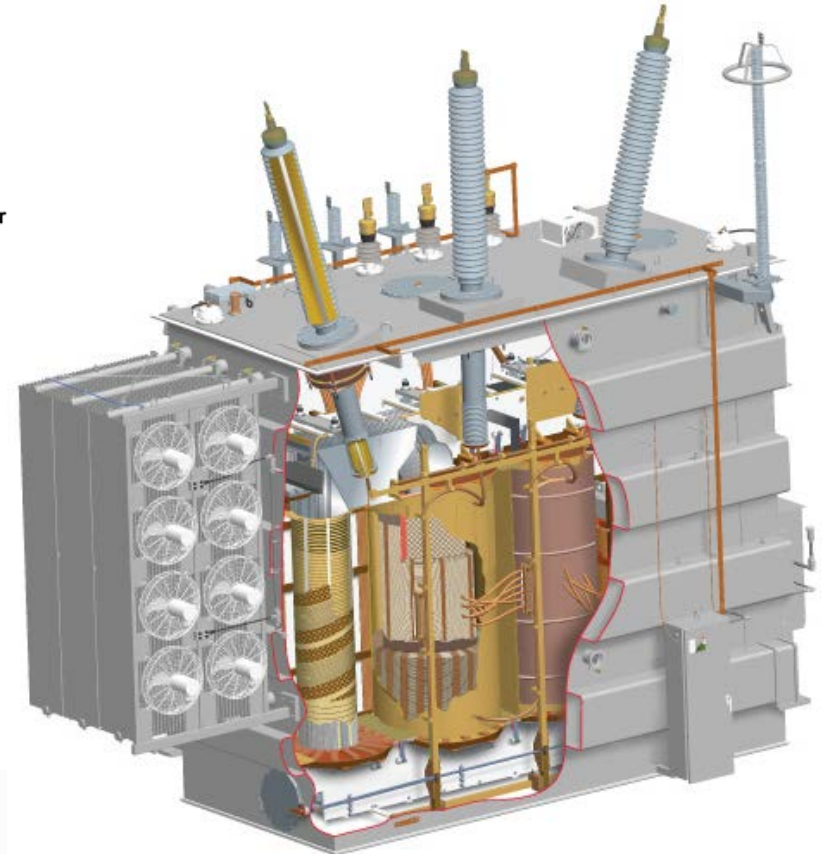

Oil circulation removes heat from the windings.

Non-Directed Oil Flow

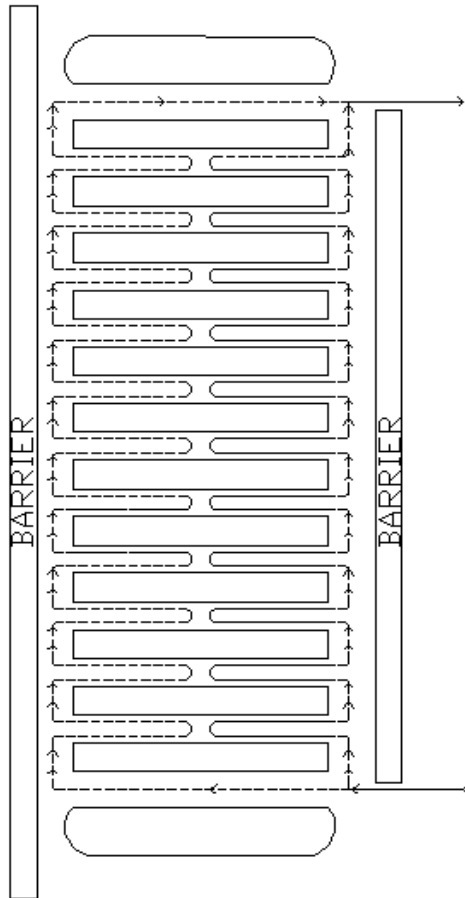

Oil is free to find its own path from the bottom of the winding to the top of the winding.

Directed Oil Flow

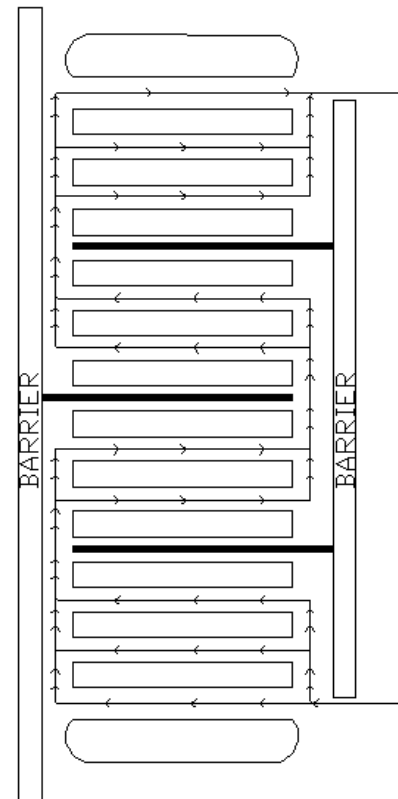

Washers are strategically placed in the winding to direct the oil flow.

Natural Circulation

- Natural circulation, or thermo-siphon, depends on the density change of oil from temperature variation to produce oil flow
- Typical IEEE designations include ONAN / ONAF



Forced Circulation

- Using pumps and ducting to create higher directed oil flow through the windings
- Higher cooling efficiency
- Typical IEEE designations
 - OFAF
 - OFWF
 - ODAF
 - ODWF



- Radiators are most commonly used to increase the amount of exposed oil surface area to the surrounding air in order to increase the heat exchange rate efficiency
- If dictated by loading or space requirements, heat exchangers OFAF that employ pumps and fans, or OFWF (water coolers) can be used, at higher cost
- Fans are relatively inexpensive means to increase the rate of heat dissipation from the radiators by increasing the volume of air moving over the radiator surface
- Noise generated by the cooling fans varies with the blade design and speed of the cooling fans and often becomes a limiting factor in transformer loading and overall size

Oil Preservation Systems

Sealed Tank Design

- Requires a gas space for expansion of the mineral oil
- Shipped from factory with nitrogen
- Designed for a max operating pressure of 8 psi with a 125% safety factor(10 PSI)
- Supplied with a pressure / vacuum relief device as overpressure protection
- IEEE minimum requirement

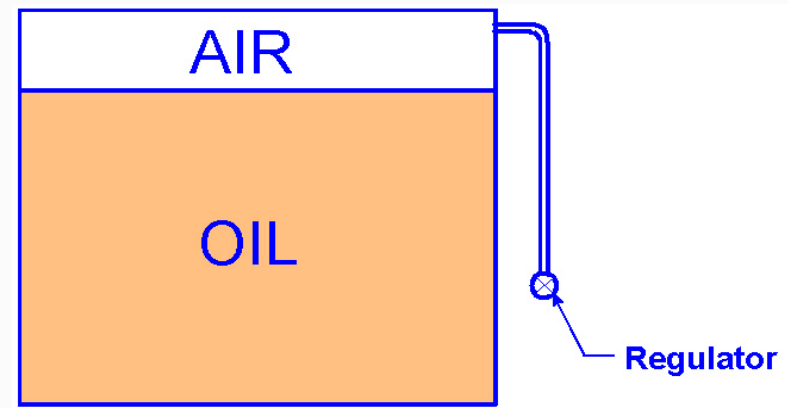

Oil Preservation Systems (cont.)

Nitrogen Regulated Design

- Requires source of nitrogen
- Regulator system to maintain positive pressure
- By customer specification

Conservator Tank Design

- Separate oil reservoir (overflow)
- Requires desiccant breather and air bladder to ensure oil is not exposed to O₂ and water
- By customer specification

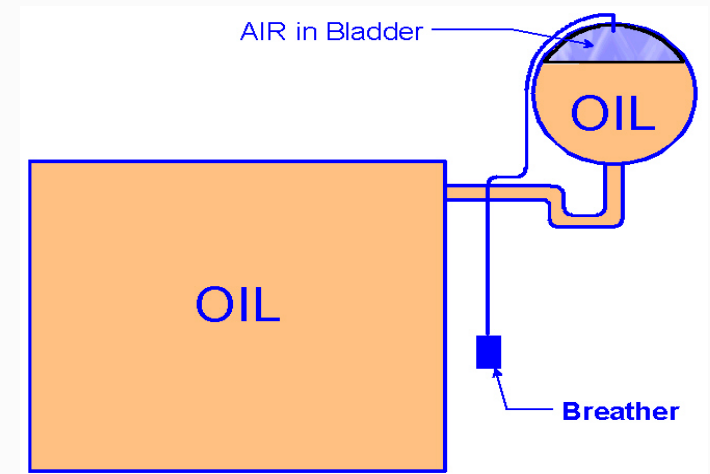
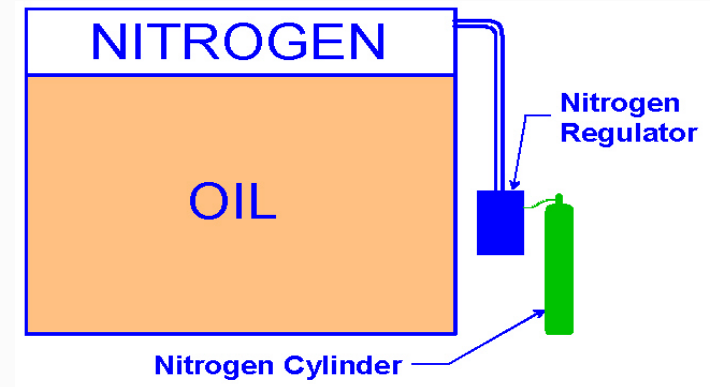

Industry Guides

C57.91-1981 Distribution Transformer	⇒	
C57.92-1981 Power Transformer		IEEE C57.91-2011 IEEE Guide for Loading Mineral-Oil-Immersed Transformers and Step-Voltage Regulators
C57.115-1991 Power Transformer >100MVA		

NOTE: IEC Publication 60076-7 is a 2005 update of IEC Pub 60354-1991

Theoretical Life \Rightarrow

$$Life = \exp\left(\frac{15000}{HST + 273} - 27.604\right)$$

Where, Life = Life in hours at temperature HST
 HST = Hot Spot Temperature in °C

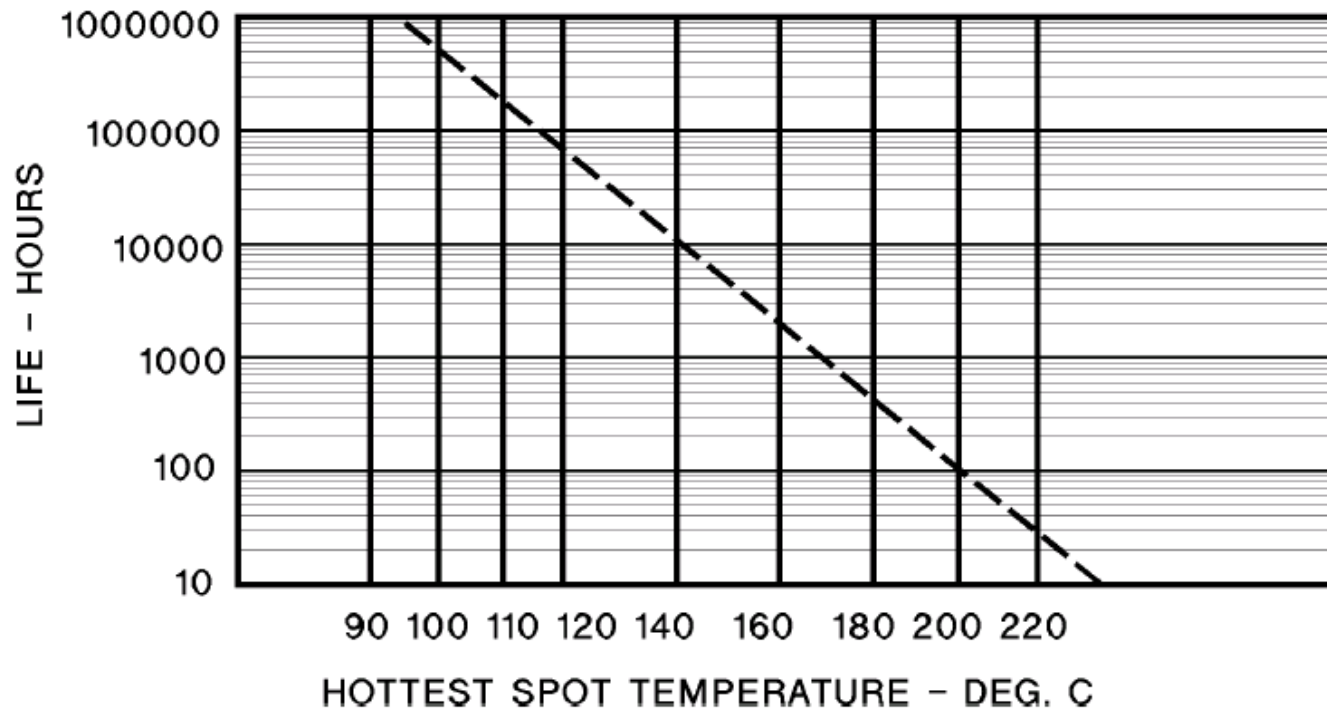

Source: C57.91-2011 IEEE Guide for Loading Mineral-Oil-Immersed Transformers and Regulators

Table 2—Time durations in hours for continuous operation above rated hottest-spot temperature for different loss of life values

Hot spot temp °C	FAA	Percent loss of life ^a						
		0.0133 ^b	0.02	0.05	0.1	0.2	0.3	0.4
110	1.00	24	—	—	—	—	—	—
120	2.71	8.86	13.3	—	—	—	—	—
130	6.98	3.44	5.1	12.9	—	—	—	—
140	17.2	1.39	2.1	5.2	10.5	20.9	—	—
150	40.6	0.59	0.89	2.2	4.4	8.8	13.3	17.7
160	92.1	0.26	0.39	0.98	1.96	3.9	5.9	7.8
170	201.2	0.12	0.18	0.45	0.89	1.8	2.7	3.6
180	424.9	0.06	0.08	0.21	0.42	0.84	1.27	1.7
190	868.8	0.028	0.04	0.10	0.21	0.41	0.62	0.82
200	1723	0.014	0.02	0.05	0.10	0.21	0.31	0.42

a - Based on a normal life of 180,000 hrs (20.5 yrs). Time durations not shown are in excess of 24 h.

b - This column of time durations for 0.0133% loss of life gives the hours of continuous operation above the basis-of-rating hottest-spot temperature (110°C) for one equivalent day of operation at 110°C.

FAA – Aging Acceleration Factor

Source: C57.91-2011 IEEE Guide for Loading Mineral-Oil-Immersed Transformers and Regulators

Basis	Normal Insulation Life	
	Hours	Years
50% retained degree of polymerization in insulation	65,000	7.42
25% retained degree of polymerization in insulation	135,000	15.41
DP = 200 End of Life of Insulation	150,000	17.12
Interpretation of distribution transformer functional life test data (former IEEE Std C57.91-1981 criterion)	180,000	20.55



6 to 8°C reduction in hot-spot temperature doubles theoretical life.

- Aging of insulation materials is dependent on more than just hot-spot temperature:
 - Moisture
 - Oxygen
 - Temperature
 - Time
- Proper application of oil preservation systems and maintenance can minimize the moisture and oxygen content
- Proper loading practices can minimize the hot-spot temperature



- Defined as “conditions under which the transformer does not function as intended”
- Overloading impacts functional life:
 - Bubbles in the oil can lead to dielectric failures (hot-spot temp)
 - Accelerated aging of gasket materials can lead to oil leaks
 - Accelerated aging of insulation can lead to dielectric or mechanical failures when exposed to fault conditions
 - Tank pressure build-up can cause gasket leaks and possible PRD operation (average oil temp)
 - Other loading related issues include current carrying components ratings, CT saturation, lead heating and leakage flux overheating



- Sources of bubbles:
 - Gasses dissolved in oil
 - Gasses generated from decomposition of insulation
 - Water vapor from paper insulation in windings
- Sudden release of gas/vapor as bubbles is possible under overloading conditions, depending on dissolved gas levels and moisture content of the insulation



MATHEMATICAL RELATIONSHIP

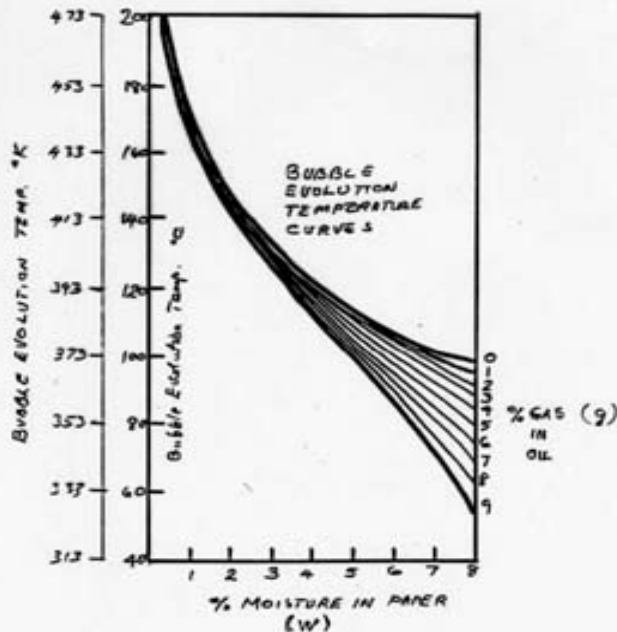

$$T (^{\circ}K) = \left[\frac{6996.7}{22.454 + 1.4495 \ln W - \ln P} \right] - \left[\exp(0.473 W) \times \frac{(g)^{1.585}}{30} \right]$$

Temperature for bubble formation is a function of the following:

- Moisture content of insulation
- % of dissolved gasses in oil
- Can occur at normal operating temperatures

Source: IEEE T&D Conference in Atlanta in 2001 by T.V. Oommen
EPRI reports EL-6761, March 1990, EL-7291, March 1992

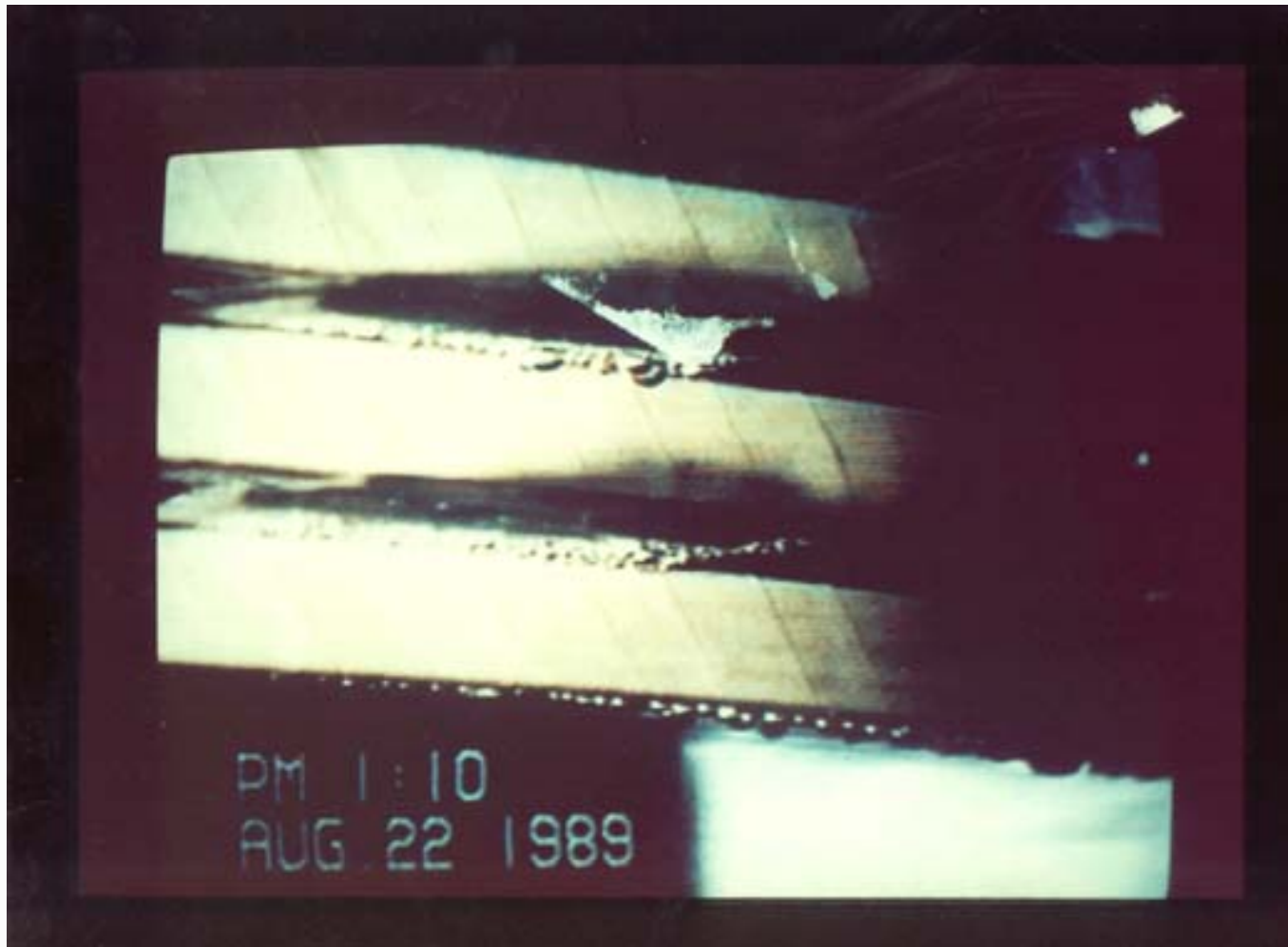

Source: IEEE T&D Conference in Atlanta in 2001 by T.V. Oommen EPRI reports EL-6761, March 1990, EL-7291, March 1992

Summary from Oomen's reports on bubbles:

- Bubble generation from overload is mostly due to water vapor released from paper insulation
- Gas-blanketed units and conservator units show little difference in bubble evolution at low moisture levels
- Increasing gas saturation in oil lowers bubble evolution temperature only at high moisture levels
- Accepting 140°C as hot-spot temperature limit appears to be valid for moisture content above 1.5%
 - 1995 CIGRE survey found similar practice (140°C limit)

- Tank and radiator gaskets
- Insulation system
 - Thermal aging process
- Winding and top oil temp
- Tap changers
 - DETCs
 - LTCs
- Main and LTC Tank
 - Oil level
- Ancillary equipment
- Bushings
 - Oil level
 - Temperature
- Dissolved gas analysis
- Oil quality
- Thermal
 - Fans
 - Pumps
- CTs

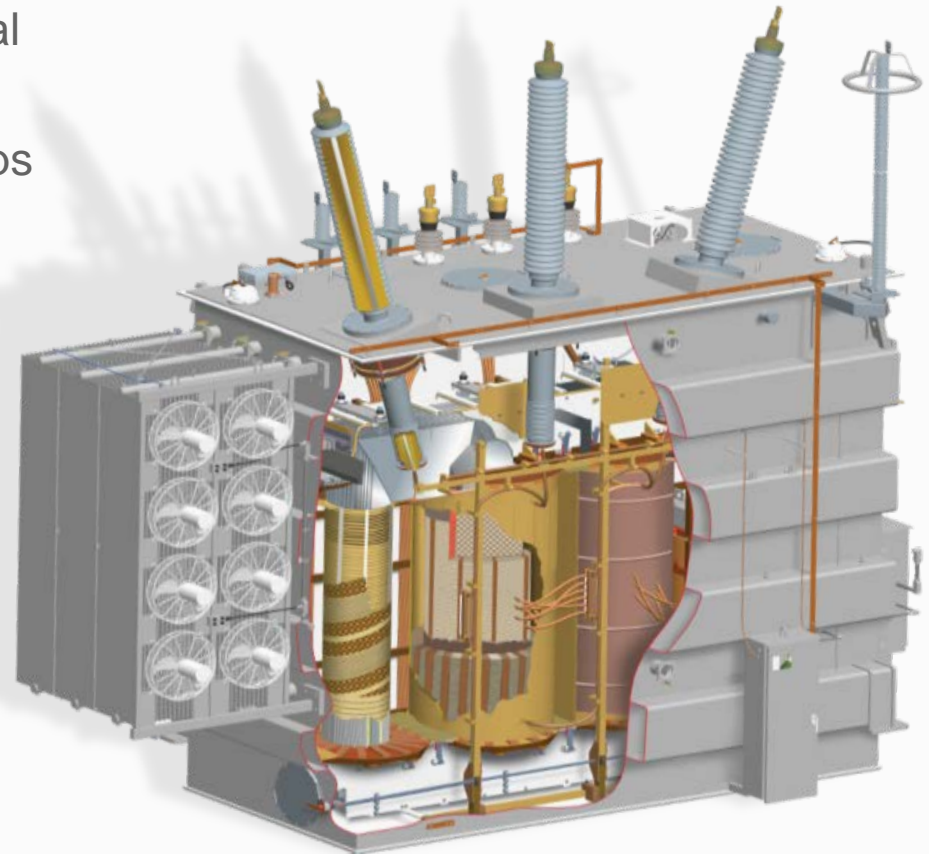

Understanding the failure modes helps determine “what” to monitor and “how often”

De-energized tap changers may be susceptible to contact coking:

- Excessive load
- Poor oil quality — film on contacts
- On-line and periodic DGA / oil quality testing can detect



Monitoring: Load Tap Changers

PARAMETER MEASURED	ON-LINE	OFF-LINE
Range of Operation (operation through neutral?)	✓	✓
Maximum Current vs. LTC Rating	✓	✓
Oil Quality		✓
Dissolved Gas Analysis	✓	✓
Desiccant Breather (Saturated / Plugged)	✓	✓
LTC Tank vs. Main Tank Temperature Differential	✓	
Infrared Scan (hot-spots, temperature stratification)	✓	

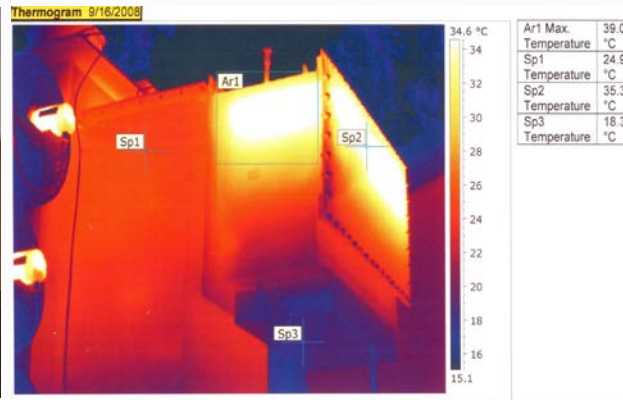
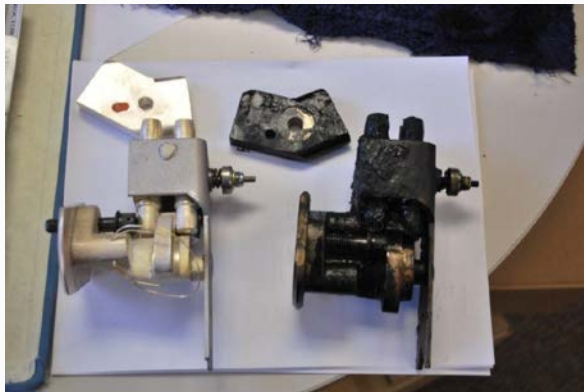

Monitoring: Controls



- Temperatures
 - Top oil temperature
 - Ambient temperature
 - Winding hot-spot calculation (each winding)
 - Direct winding temperature from fiber optic sensors
 - Bottom oil temperature

- Cooling System
 - Fan / Pump failure
 - Fan / Pump run hours
 - Cooling contactor fail / trip
 - Cooling breaker trip

- Core & Coil
 - Dissolved gas
 - Moisture in oil
 - Insulation loss of life

- Alarms & Ancillaries
 - Sudden Pressure
 - Pressure Relief
 - Low / High oil
 - Nitrogen pressure

- Load Tap Changer
 - Tap position indication
 - Tap operations counter
 - Time since last through neutral
 - Delta T
 - Oil level

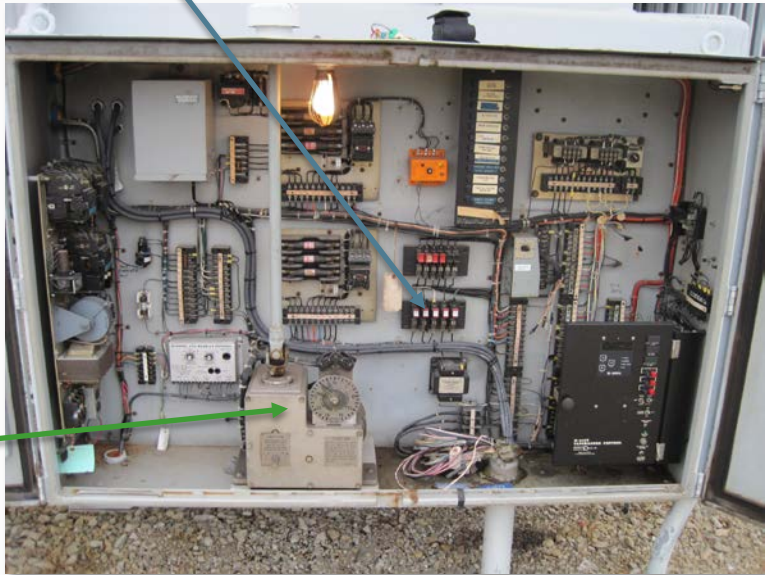

- Overloading transformers beyond nameplate is inevitable
- Follow loading guide on hot-spot limits
- Specify overload capability when purchasing a transformer and verify through OEM design calculations and factory testing
- Proper maintenance of the transformer and accessories is critical:
 - Keep moisture in insulation at a minimum
 - Maintain the oil preservation system (limit exposure to oxygen and moisture ingress)
 - Repair / Eliminate oil leaks
 - Keep radiators' / coolers' air path clean and free of obstructions and operational
 - Verify calibration of the temperature gauges
- Increased monitoring of overloaded units may be needed based on criticality
 - On-line real-time (oil and winding temp, DGA, cooling equipment)
 - Periodically (infrared, DGA, visual inspections)

Questions?

Thank you!